

SERVICE MANUAL

SECTION I

The
HYDRAULIC SYSTEM
of the
CONVERTIBLE



Additional copies of this section of the Service Manual may be obtained from any Packard Zone Parts and Service Department at 25 cents per copy.

INDEX

DESCRIPTION AND OPERATION

SERVICING THE HYDRAULIC SYSTEM

Paragraph

Battery	1
Circuit Breaker	12
Control Switches	16
Unit Replacement	17
Door Window	
Adjustment	8
Alignment	6
Regulator Assembly Replacement	18
Fluid	
Leakage	4
Level	2
Replacement	3
Leaks, Checking for	5
Operating Cylinder Solenoid Valve	15
Power Unit	10
Pump Pressure	11
Quarter Window	
Adjustment	9
Alignment	7
Regulator Assembly Replacement	19
Seat, Front, Regulator Assembly	20
Solenoid Relay Switch	13
Top Operating	
Cylinder Replacement	22
Valve and Switch	14
Trouble Shooting	23
Window and Seat Operating Cylinder	21

TOP ADJUSTMENTS

Before Installing New Fabric	29
Header	26-28
Side Rail	24-25
at Quarter Window	27

DESCRIPTION AND OPERATION

The 1948 Packard Convertible is equipped with an Electro-Hydraulic power system which is used to open and close the windows, raise and lower the top, and adjust the position of the front seat. These operations may be performed at any time, whether the engine is running or stopped, by means of conveniently located switches.

This system consists of an electrically driven pump and reservoir assembly; actuating cylinders for each window, the top, and the front seat; and the necessary tubing to connect these cylinders with the power unit.

The pump and reservoir assembly is mounted on the engine side of the dash on rubber supports. This method of mounting prevents the transmission of vibration from the pump to the body.

The pump unit consists of the motor, the pump assembly, and the reservoir, which is held in place by means of a bail. The intake of the rotary type pump is fitted with a baffle which prevents draining of the pump assembly when the reservoir is removed for servicing. This baffle also reduces the danger of particles of dirt, which may accumulate in the bottom of the reservoir, from being picked up by the pump.

The window and seat operating cylinders are the single-action type in which the pressure is always between the piston and the closed end of the cylinder. This construction eliminates the danger of leakage past the piston rod seal. The closed end of the cylinder is fitted with a spring seated solenoid valve which, when energized, opens to allow fluid to flow in or out of the cylinder.

When the windows are raised or the seat moved forward, the movement of the switch button causes the solenoid valve to be opened and the pump motor to start. Pressure entering the cylinder forces the piston upward raising the window or moving the seat forward.

When the windows are closed or the seat moved rearward, the solenoid valve is opened and the piston and window pulled to their downward

position by means of coil springs. This downward movement of the piston forces the hydraulic fluid through the open solenoid valve and back to the reservoir.

The top operating cylinders are double-acting cylinders in which the piston is forced upward to raise the top by means of hydraulic pressure and forced downward by hydraulic pressure to lower the top. Leakage at the upper end of this cylinder, that is, between the piston and the open end of the cylinder, is prevented by a seal held into the open end of the cylinder by means of a snap ring.

The flow of fluid to these cylinders is controlled by means of a combination distributing valve and switch. When the top control knob is placed in the position to lower the top the switch closes the circuit to the hydraulic pump. At the same time, the distributing valve is positioned to direct the fluid to the upper end of the top actuating cylinder. This forces the piston downward causing the top to be pulled down into its well.

When the knob is placed in position to raise the top, the pump is started and the fluid directed to the lower end of the cylinder causing the piston to move upward, thus raising the top.

SERVICING THE HYDRAULIC SYSTEM

The following paragraphs describe the possible causes and corrections for various service difficulties which may be encountered in the Electro-Hydraulic system used on the new Convertibles to operate the windows, front seat, and the top.

All parts of the hydraulic system, including connections, are shown in the schematic view, figure 27.

A complete wiring diagram for the entire hydraulic system is shown in the schematic view, figure 28.

When servicing the hydraulic system to determine the cause of some disorder which results in faulty operation of these power-operated assemblies, it is important that attention be given to the proper alignment of window glasses and channels, seat tracks, and other parts

which contribute toward satisfactory operation of the power system.

In many cases, the methods for correcting misalignment, binding, etc., largely depend upon the judgment of the mechanic since a specified repair procedure will not always correct the condition. However, the more prominent causes of misalignment and their corrective procedures will be listed among the following paragraphs.

The servicing of the hydraulic system and the adjustment of the power-operated assemblies are as follows:

1—BATTERY

When servicing the hydraulic system, the battery should first be tested before proceeding with further investigations. The power system will not operate properly on a "weak" battery and the entire system becomes inoperative if the battery gravity reading is below 1.175.

2—FLUID LEVEL

The fluid should be close to the level mark in the reservoir which is held to the bottom of the pump by a snap-on spring bail.

The first indication of insufficient fluid is a noisy power unit. A rapid chatter will be set up inside the pump whenever the windows are raised, the seat moved forward, or the top operated.

Before removing the reservoir to check the fluid level or when fluid is to be added or changed, all windows should be lowered and the seat moved to its rearmost position. This is necessary in order to discharge the fluid from the window and seat operating cylinders which should be empty when the fluid level is checked or fluid added. If the fluid is low, fill to level mark.

When it is necessary to add fluid, use Packard Brake Fluid. *Never use mineral oil of any kind in this system.* Mineral oil will cause swelling and deterioration of the synthetic rubber seals and early failure will result.

3—FLUID REPLACEMENT

The fluid should be replaced at 5000-mile intervals or each spring and fall. The reservoir should be cleaned out with alcohol to remove any abrasive sludge which may have settled in the reservoir.

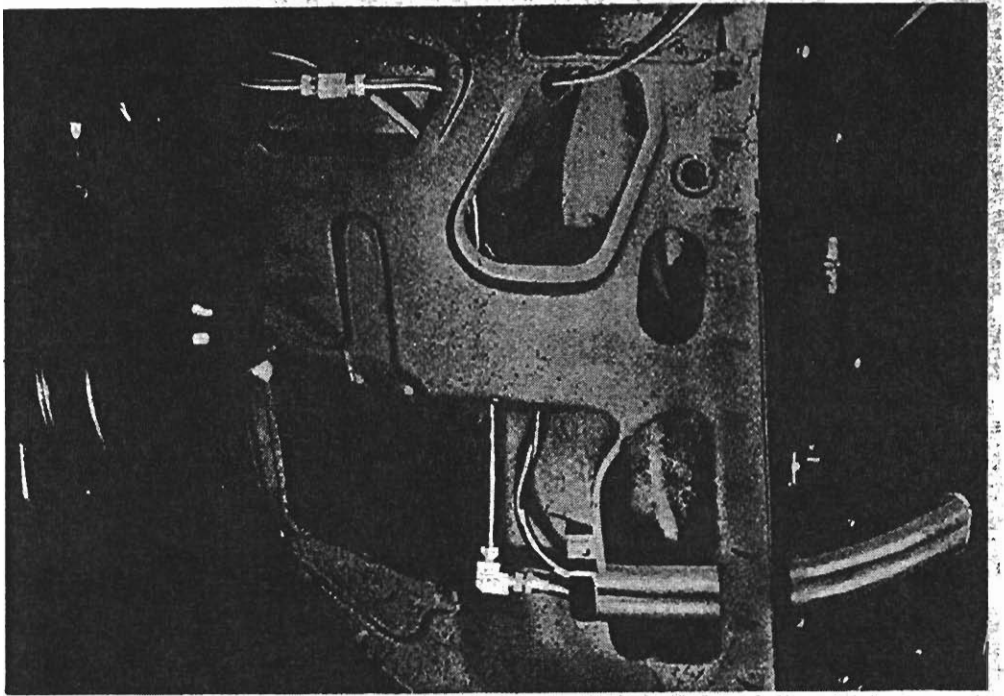

Fig. 1—Hydraulic Fluid at Base of Inner Panel Indicates Leak at One of Two Connections Shown.

4—FLUID LEAKAGE

Since it is important that the proper amount of fluid be kept in the system at all times, the system should be free from leaks. A leak should be eliminated as soon as possible for two reasons. First, the steady loss of fluid will eventually cause faulty operation of the window, seat, and top operating mechanisms. Second, the hydraulic fluid is damaging to painted surfaces. A leak such as at a connection inside the door panels may result in the fluid emerging from the drain channels and damaging the paint on the floor side sill panel.

5—CHECKING FOR LEAKS

When checking for leaks, the most readily accessible fittings and connections should first be inspected. These include the connections at the pump, which is attached to the front of the dash panel, and at the top operating valve connections under the instrument panel.

Leaks at connections inside the door panels may be checked by feeling along the door lower weatherstrip at the drain channels.

If no leaks are detected at the points mentioned, the front and rear seat cushions and the floor mats should be removed and all connections and tubing checked.

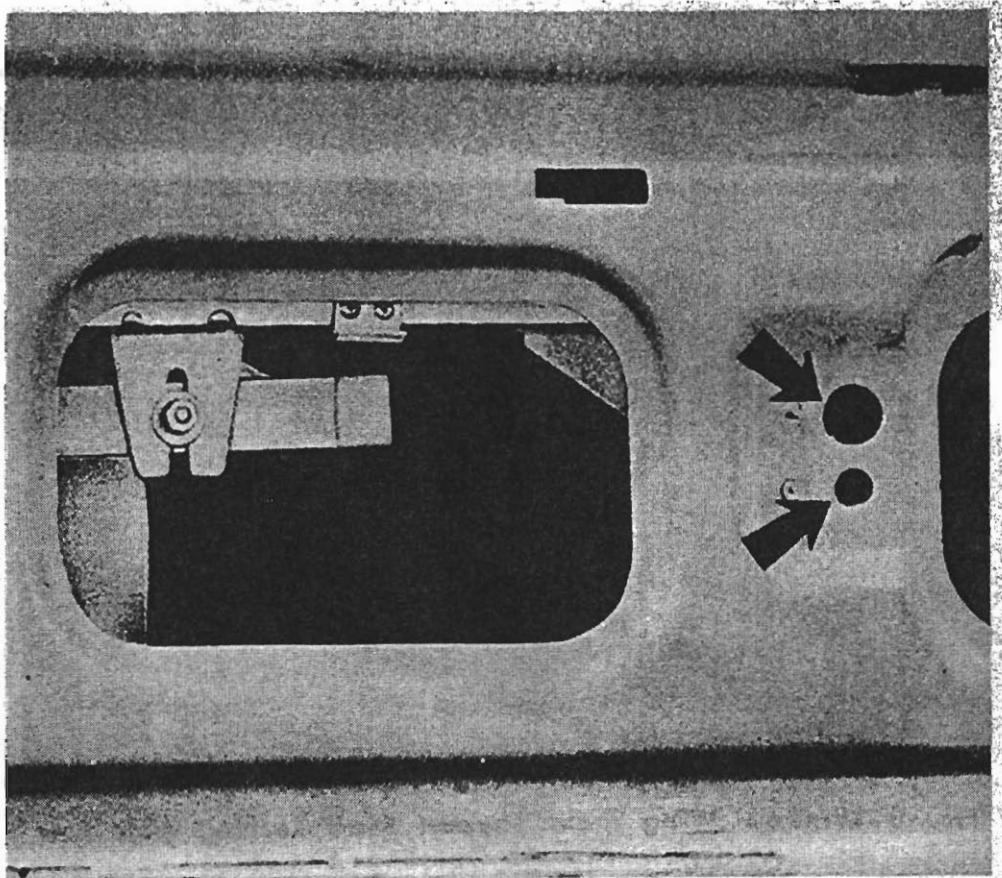

Fig. 2—Access to Channel Lower Retaining Screws Is Afforded Through Openings Shown.

Figure 1 shows the connections behind the cowl side trim panels. After the floor mat has been removed, the presence of hydraulic fluid at the base of the inner panel indicates a leak at one of the two connections. It then will be necessary to remove the trim panel in order to correct the leak.

The location of all fluid tubing connections are shown in figure 27. This illustration may be used as a ready reference when tracing the source of a leak.

6—DOOR WINDOW ALIGNMENT

If the door window binds while being raised or lowered, the window front channel may be improperly positioned. The lower end of the channel is held in place by retaining screws which are accessible through the openings shown in figure 2. Elongated holes provide a fore-and-aft adjustment of the lower end of the channel so that proper alignment may be obtained. If this adjustment is to be changed, first loosen the two window wing front support shaft locking nuts which are located above and below the support bracket and which are acces-

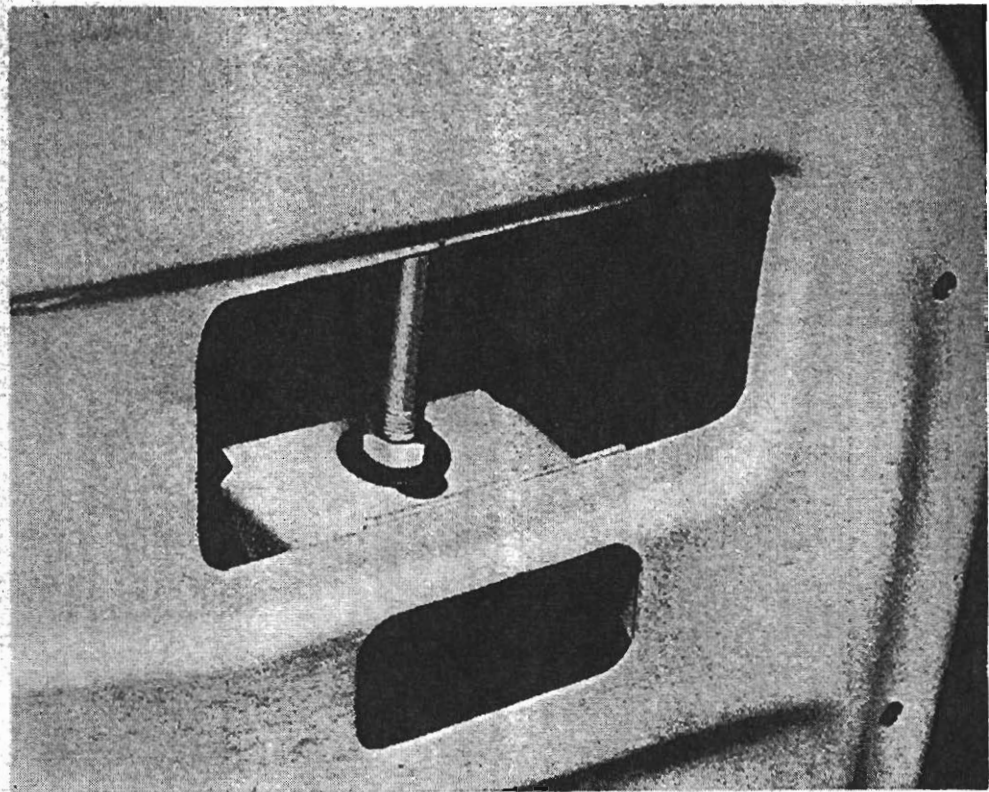

Fig. 3—Window Wing Front Support Shaft Locking Nuts Are Accessible Through Openings Shown.

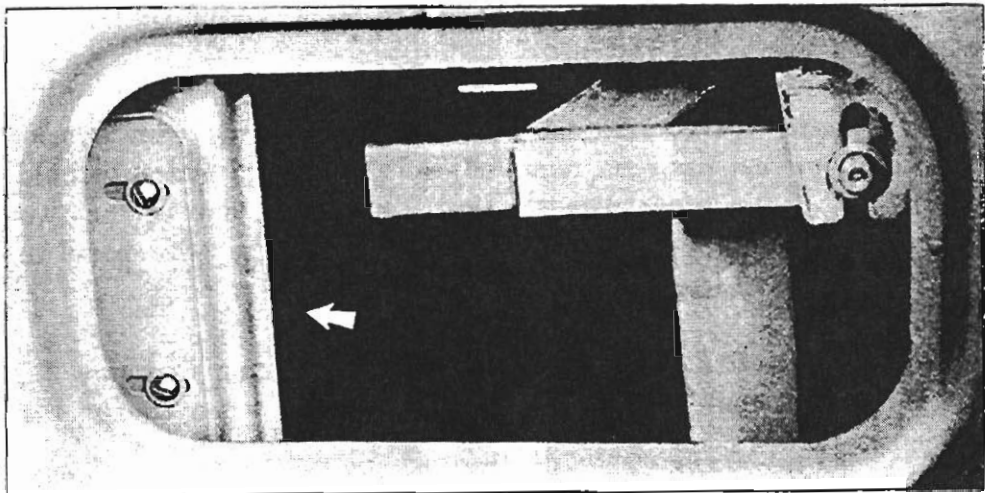

Fig. 4—Loosen Three Channel Retaining Screws, then Shift Assembly to Proper Position.

sible through the openings shown in figure 3. Also loosen the three retaining screws of the channel shown in figure 4. The complete window wing and door window channel assembly then can be shifted to obtain proper fore and aft door window alignment.

The door window side adjustment is controlled by the adjusting screw at the front face of the inner door panel as shown in figure 5. The

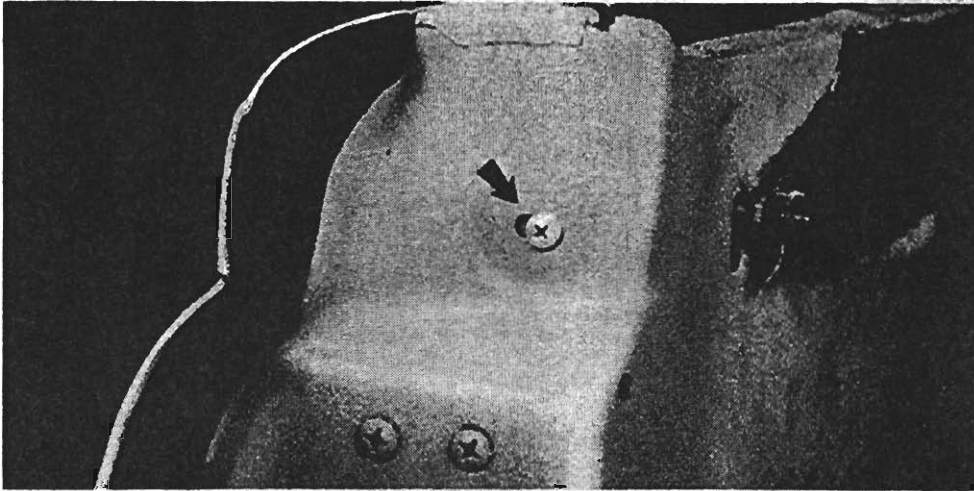

Fig. 5—Adjusting Screw on Front Face of Inner Panel Controls Door Window Side Adjustment.

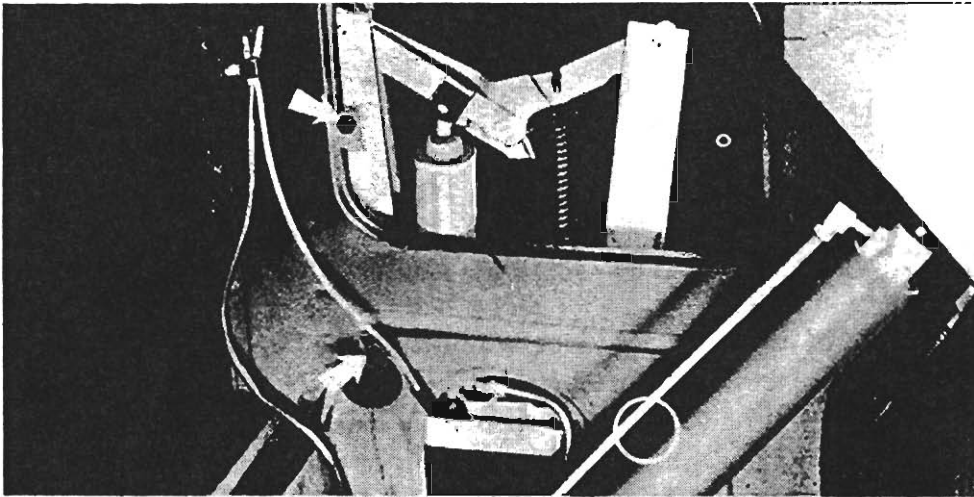

Fig. 6—Quarter Window Is Aligned by Three Cap Screws. Third Screw Is Behind Panel at Circle.

elongated hole in the door panel at this point permits a side to side movement of the upper end of the window rear guide. The window may be centralized in its opening by loosening the adjusting screw and shifting the upper end of the guide as required.

7—QUARTER WINDOW ALIGNMENT

The rear quarter window very rarely requires a change in adjustment or alignment after its original installation.

In the fully closed position, a gap at the front of the frame of the quarter window, in relation to the rear of the door window frame, may be corrected by loosening the three cap screws indicated in figure 6 and moving the regulator assembly up or down. If the glass goes

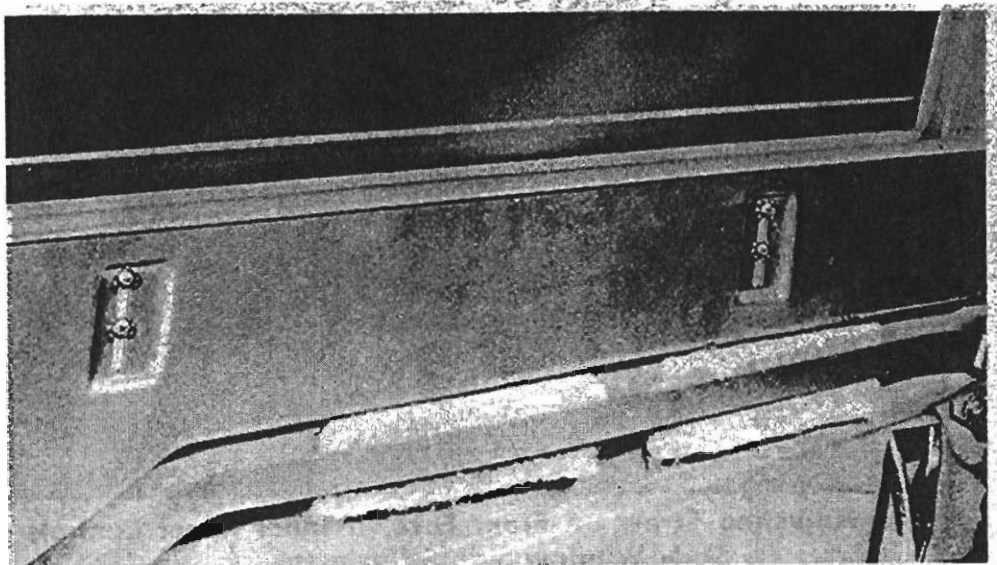

Fig. 7—Four Screws Retain Stop Brackets which Control Door Window "Up Limit" of Travel.

down too far or not far enough, move the regulator assembly forward or back. The cap screw, not visible in the illustration, is accessible from behind the inner panel at the position indicated by the circle.

8—DOOR WINDOW ADJUSTMENT

The limit of travel of the door window in the "up" position is governed by the two stop brackets held in place by the four retaining screws shown in figure 7. If, when fully raised, the top of the door window is too high in relation to the top of the window wing frame, loosen the screws and lower the brackets. If the window is too low, raise the brackets. When raising the window, after changing the position of the stops, the action of the window should be noted when it reaches the limit of its travel. Both stops should be contacted at the same time. If one stop is contacted before the other, the window may cock in the channels.

The position of the window in the "down" position is controlled by the two retaining nuts indicated in figure 8. If, when fully lowered, the top of the window projects above the opening in the door, loosen the two nuts and move the window downward until the top of the window is flush with the opening in the door. When this adjustment is required, recheck the window travel in the "up" position and adjust if necessary.

9—QUARTER WINDOW ADJUSTMENT

See "Quarter Window Alignment."

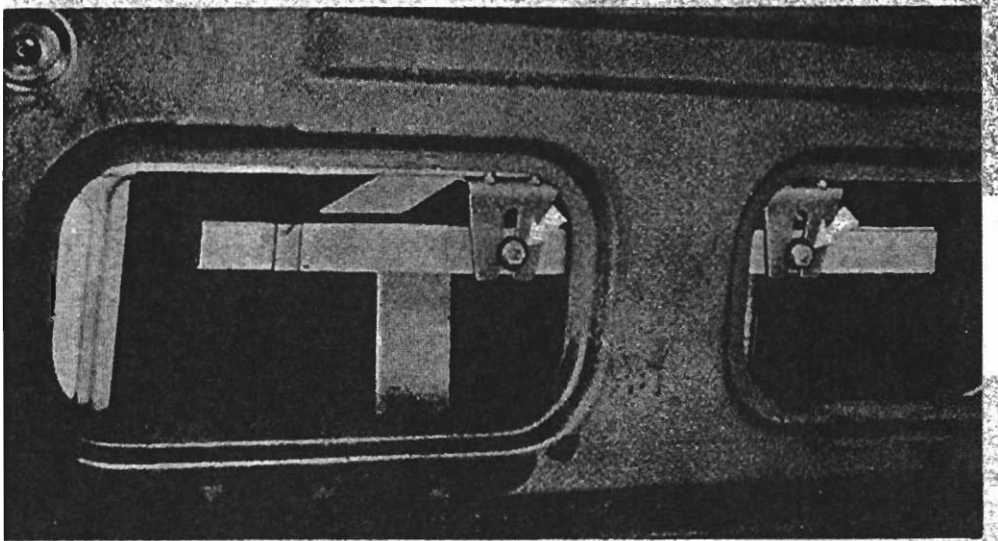

Fig. 8—Arrows Indicate Retaining Nuts which Control "Down" Position of Door Window.

10—POWER UNIT

The power unit incorporates a solenoid-controlled electric motor which rotates internal gear rotors to create the pressure required to operate the power-operated assemblies.

The motor armature is serviced in the same manner as is the engine starting motor armature.

Service parts for the power unit include the solenoid switch, armature, frame and field assembly, pump assembly, reservoir, and the reservoir bail (See figure 9).

11—PUMP PRESSURE

The pump pressure may be checked with a suitable gauge connected at any convenient point in the system. The maximum pressure must not exceed 260 pounds and in no case should it be changed to provide a higher pressure.

The window and seat operating cylinders incorporate a spring-seated solenoid valve which, when energized, opens to allow fluid to flow in or out of the cylinders. If the pump pressure is too high, one or more of the cylinder valves may be forced off its seat. When this occurs, two windows may raise and the seat may move forward when a control button is moved to raise one particular window.

If the pressure is too low and the windows, seat, and top all operate

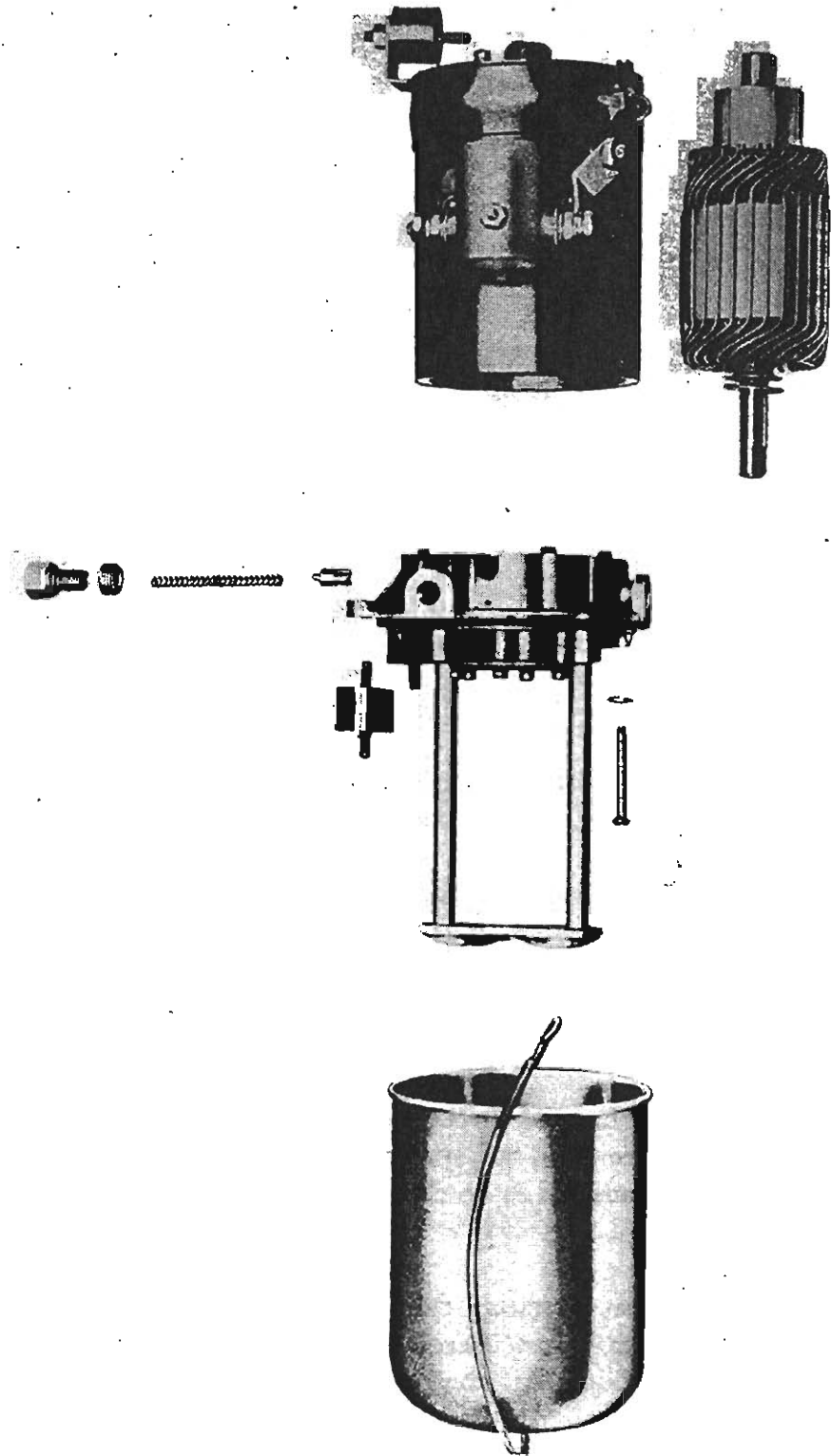

Fig. 9—Exploded View of Hydraulic Pump Unit. Note Pump Assembly Regulating Valve Position.

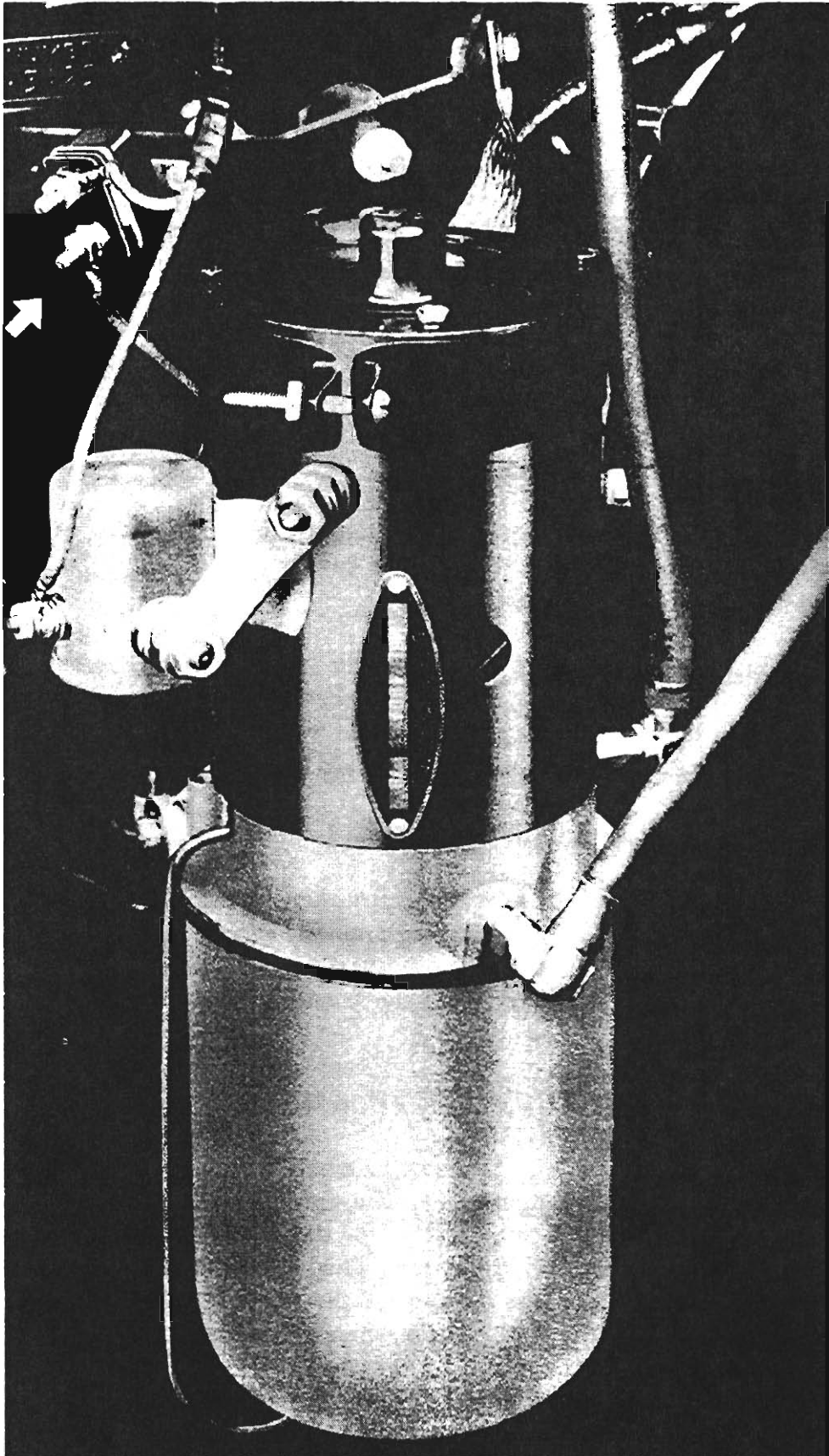

Fig. 10—Circuit Breaker on Pump Upper Bracket Guards Against Short Circuit Damage.

slower than normal, remove the copper plated hexagon plug from the rear of the pump casting and remove the regulating valve and spring (See figure 9). After the plug and spring have been removed, a stuck valve may be extracted with "mechanical fingers."

NOTE

Exercise care to prevent losing any of the spacers installed between the head of the plug and the pump casting since these spacers must be used when the regulating valve is reinstalled.

Inspect the valve and the opening in the pump for dirt or any other foreign matter which might cause the valve to stick.

12—CIRCUIT BREAKER

A "Klixon" circuit breaker, which is attached to the pump upper bracket, figure 10, is connected in the battery circuit to protect the electrical system against short circuits.

A defective circuit breaker will make the entire system inoperative. When this condition exists, short across the two terminal posts of the circuit breaker and operate one of the windows. If the window operates normally, the circuit breaker should be replaced.

13—SOLENOID RELAY SWITCH

The solenoid relay switch, attached to the pump motor frame assembly, is similar to the solenoid switch used on the engine starting motor. If the pump motor does not operate, short around the motor solenoid switch. If the pump operates while the solenoid switch is shorted out, replace the switch.

14—TOP OPERATING VALVE AND SWITCH

The top operating valve and switch assembly is located under the instrument panel (See figure 11). The function of this unit is to direct the flow of fluid to either end of the top operating cylinders thereby raising or lowering the top. This unit also incorporates a switch, which, through the medium of the solenoid relay switch on the pump, operates the pump motor when the control knob is pushed in or pulled out.

The internal switch in the valve assembly may be checked for proper operation by connecting a jumper wire to the two terminals, one on the bottom and one on the side of the valve assembly. If the top oper-

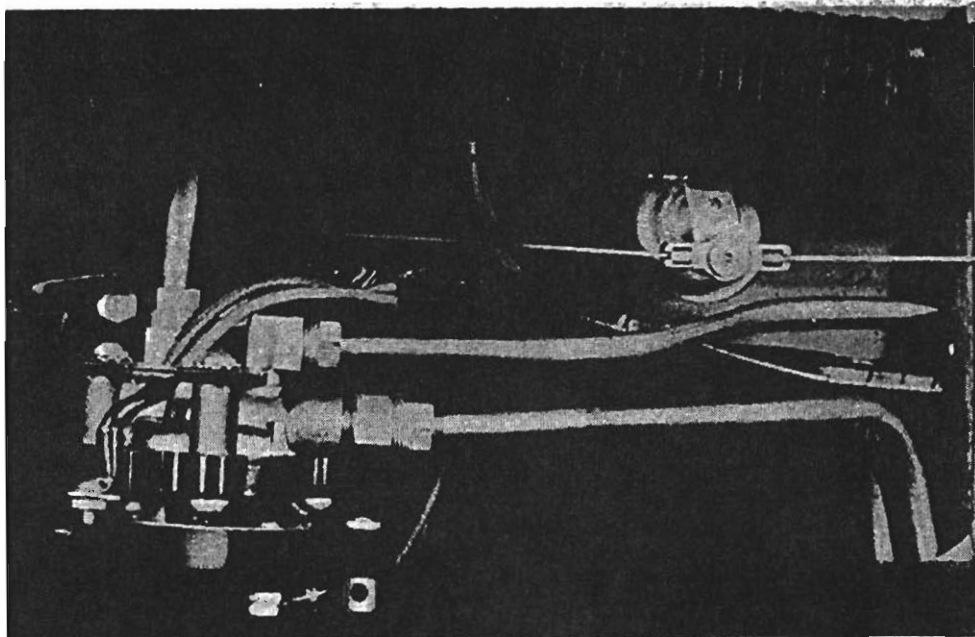

Fig. 11—Top Operating Valve and Switch Assembly Is Located on Left Side of Dash Panel.

ates normally when the control knob is pushed in or pulled out, the internal switch is inoperative and the complete valve and switch assembly should be replaced.

The control knob and rod moves the valve to change the direction of the flow of fluid and it is important that the control rod be free from binding to insure a positive return of the valve to the neutral position when the knob is released.

If the valve does not return to the neutral position, two pressure passages will be partially in register and the top will "hunch" or, in other words, try to operate when a window is raised.

15—CHECKING OPERATING CYLINDER SOLENOID VALVES

The window and seat operating cylinders incorporate a spring-seated solenoid valve which, when energized, opens to allow fluid to flow in or out of the cylinders.

When the solenoid valve is functioning properly, a loud "click" can be heard when the solenoid is energized by moving the switch control knob in either direction.

If the solenoid does not "click" check the "Douglas" terminal connections near the lower end of the operating cylinder for proper contact.

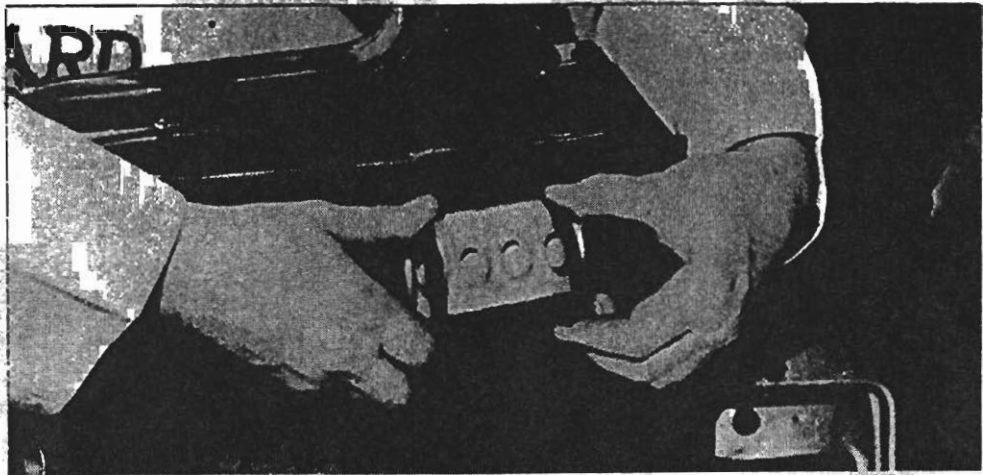

Fig. 12--Two Special Remote Control Switch Remover Tools Are Used to Remove Switch Spring Clips.

Also check for current to the solenoid.

In the event the solenoid valve is defective, it will be necessary to replace the operating cylinder since the solenoid is integral with the cylinder assembly.

16--CHECKING CONTROL SWITCHES

The window and seat control switch are held in place by spring clips and the switches may be removed using the Remote Control Switch Remover Tool, KMO-685. When the multiple switch assembly is removed, two tools are required as shown in figure 12.

The tips of the tool are inserted into the small notches at the upper and lower edges of the plastic case. By squeezing the tool, the retaining spring clips are compressed and the switch assembly may then be removed.

The switches may be checked for proper operation by using a suitable test light to indicate current continuity.

Attach one lead of the test light to the terminal marked "CYL." and ground the other lead. The bulb should light when the control knob is moved to either position.

When one lead of the test light is clipped to the terminal marked "MOT." and the other lead grounded, the light should burn when the control knob is moved upward to the window raising position.

With one lead of the test light clipped to the terminal marked

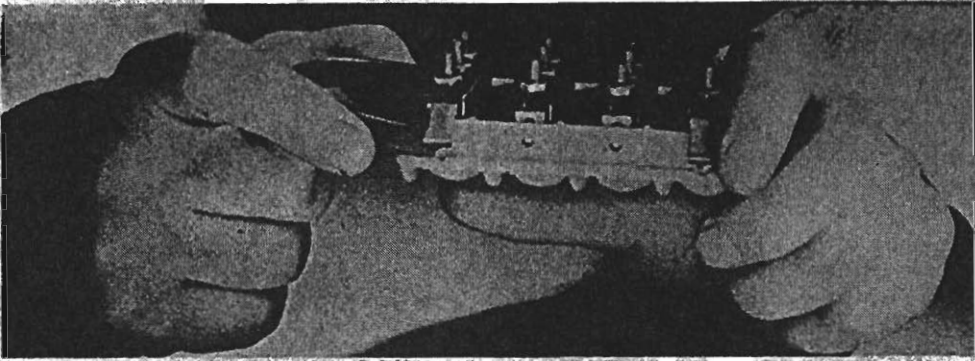

Fig. 13—Compress Unit Spring Retaining Clips with Special Tool while Pressing Control Knob "In".

"BAT." the bulb should light whenever the other lead is touched to ground.

17—CONTROL SWITCH UNIT REPLACEMENT

The following procedure outlines the steps to follow when replacing a defective switch unit in the multiple switch assembly (Single switch units are replaced in a similar manner).

Remove the switch assembly from the door trim panel as shown in figure 12.

Disconnect the wires and tag or mark each wire so they may be attached to their proper terminals when the switch assembly is reinstalled.

NOTE

If the wires are not tagged or marked when disconnected, refer to the wiring diagram, figure 28, when connecting the wires during the reassembly operation.

If an intermediate switch unit is to be replaced, first remove the end unit next to the defective intermediate unit. This is necessary since the control knob pivot pin cannot be removed from an intermediate unit without first removing the end unit.

To remove the end unit, remove the two parallel bus bars attached to the motor and battery terminals of the switch units.

Depress the unit spring retaining clips using the special tool KMO-685 and, at the same time, press the control knob inward (See figure 13).

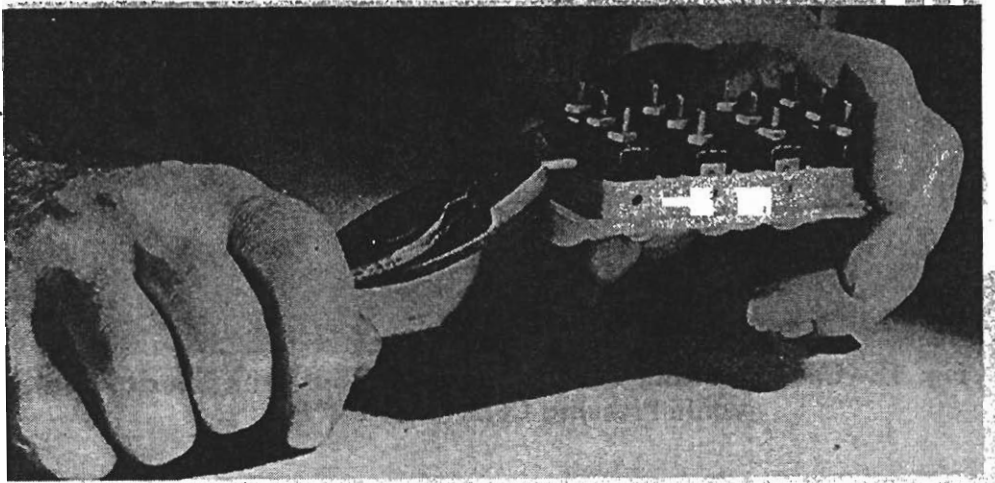

Fig. 14—Push Pivot Pin “In” until Both Ends of Pin Are Flush with Sides of Switch Unit.

Use a paper clip or piece of wire with a short bend at one end and push the control knob pivot pin out toward the end of the plastic case.

Extract the pin and remove the switch unit from the case exercising care to prevent losing the insulator which is installed between the unit and the case.

To install a replacement switch unit, place the insulator into the opening in the plastic case and then start the unit into the opening.

NOTE

The unit should be placed into the opening so that the terminal post marked “MOT.” is toward the top of the case when the complete assembly is reinstalled in the trim panel.

Place the control knob in position and line up the pivot pin hole in the knob with the holes in the switch unit. Insert the pivot pin as shown in figure 14 and push the pin in until both ends of the pin are flush with the sides of the switch unit.

Press the switch unit into the case, add the spring retaining clips at each end of the unit, and press the clips inward until the tips of the clips enter the holes in the case.

CAUTION

When replacing the regulator assemblies mentioned in the following paragraphs, do not disconnect any tubing without first disconnecting the battery to prevent accidental pumping of

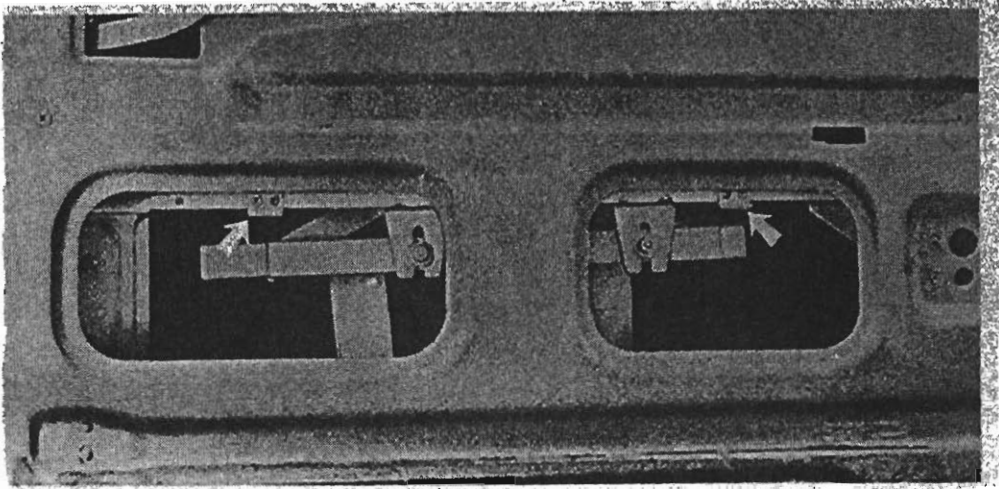

Fig. 15—Remove the Two Stop Brackets Located at the Bottom of the Window Frame.

hydraulic fluid on painted surfaces or upholstery. When tubing is disconnected, there will be a loss of fluid and, under certain conditions, the fluid may be under pressure. Always have cloths or a suitable receptacle on hand to catch this fluid and prevent damage.

18—DOOR WINDOW REGULATOR ASSEMBLY REPLACEMENT

Lower the window and remove the door window finish moulding, the inside door handle, and unscrew the locking rod knob.

Unfasten the clips around the edges of the trim panel and lift the trim panel upward to release the arm rest retaining clip which fits into an opening in the inner door panel.

NOTE

It will not be necessary to disturb the automatic window controls or wiring. Removing the trim panel this far will provide sufficient access to the inside of the door panels to remove and reinstall the regulator assembly.

Remove the two stop brackets which are attached to the bottom of the window frame (See figure 15).

Remove the three screws which hold the rear channel to the window frame (See figure 4). Slide channel toward front of door and remove.

Loosen the two retaining nuts indicated in figure 8 and lift the

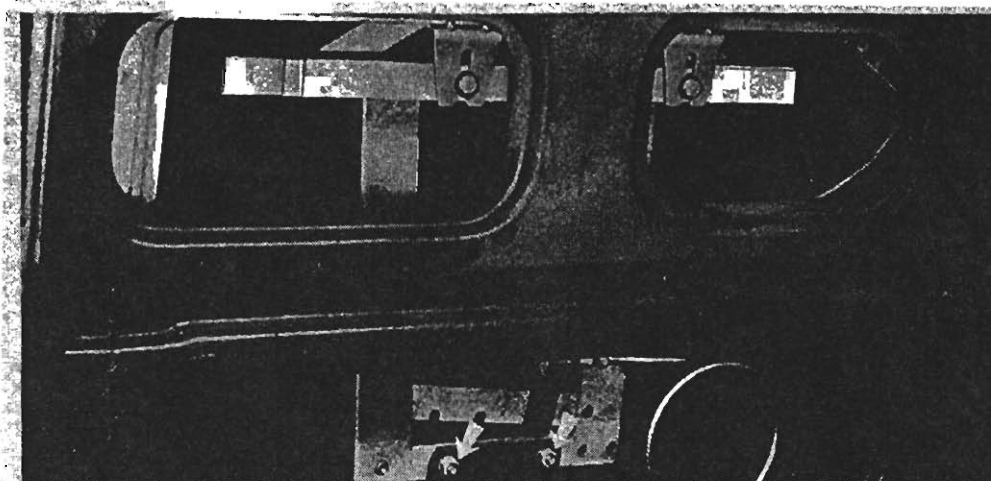

Fig. 16—Two Lower Regulator Nuts Are Removed before Extracting the Regulator Assembly.

window out of the door.

Disconnect the tube and the wire from the solenoid valve at the lower end of the operating cylinder.

Remove the regulator lower retaining nuts indicated in figure 16 and extract the regulator assembly.

Replace the regulator assembly and window by reversing the removal procedure outlined above. Adjust the window as outlined under "Door Window Adjustment."

19—QUARTER WINDOW REGULATOR ASSEMBLY REPLACEMENT

Operate the window to an approximate three-quarter "up" position. Remove the rear quarter window finish moulding, rear seat, and the retaining screws around the side trim panel.

NOTE

It is not necessary to disconnect the wires from the control switch since the wires are long enough to permit the panel to be moved out of way.

Loosen the pivot bolt indicated in figure 17. While holding the window, remove the pivot bolt and disengage the regulator arm from the slotted opening in the window frame and remove the window.

Disconnect the tube and the wire from the solenoid valve at the

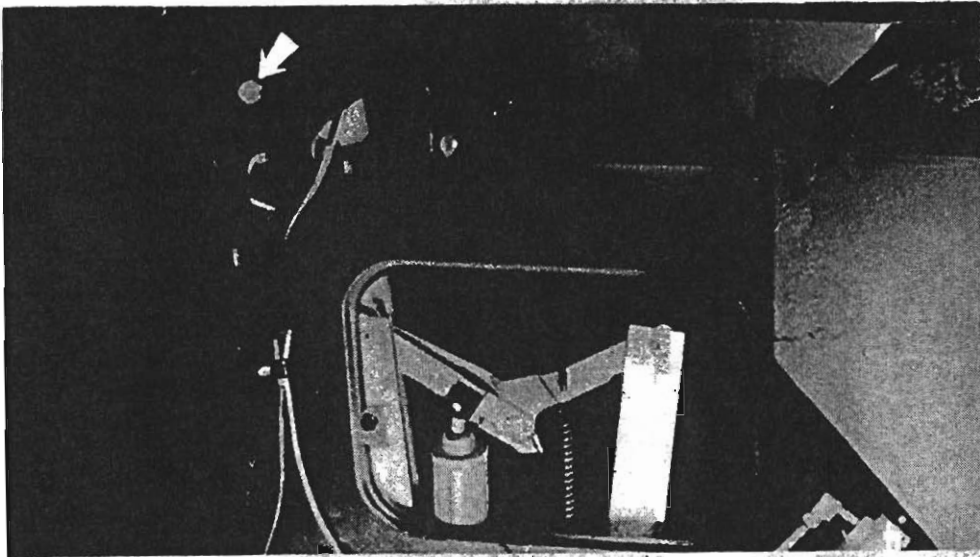

Fig. 17—Loosen Pivot Bolt and, while Holding Window, Remove Bolt and Disengage Arm.

lower end of the operating cylinder.

Remove the three regulator assembly retaining screws, two of which are shown in figure 6. The third screw is accessible from behind the inner panel at the position indicated by a circle in the illustration.

Remove the regulator through the opening in the inner panel. This may require a certain amount of manipulation since the side rear trim section closes off part of the opening in the inner panel. However, the regulator assembly may be removed without removing this rear trim section.

The regulator assembly may be reinstalled by reversing the removal procedure outlined above.

20—FRONT SEAT REGULATOR ASSEMBLY REPLACEMENT

Move the seat to the limit of its backward travel and remove the front seat cushion.

Disconnect the fluid tube and the wire from the solenoid valve at the rear end of the operating cylinder.

Remove the two regulator assembly retaining nuts shown in figure 18 and remove the assembly.

To replace the regulator assembly, reverse the procedure outlined

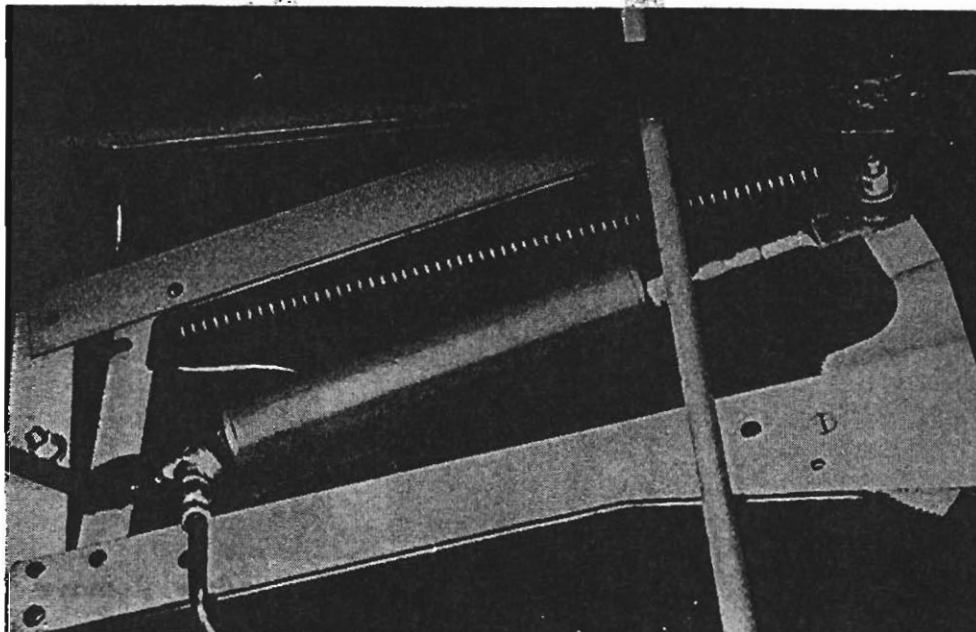

Fig. 18—Before Removing Front Seat Regulator Assembly, Both Nuts Shown Must Be Removed.

above.

21—WINDOW AND SEAT OPERATING CYLINDER REPLACEMENT

The window operating cylinders are held in place with a spring clip at each end. The seat operating cylinder has a clip only at the rear end. Clamp the regulator assembly firmly in a vise and, using the Spring Clip Remover, KMO-623, spread the spring clip as shown in figure 19.

Move the regulator operating arm (the arm which moves the window or seat) in the direction it travels when the cylinder piston rod is being extended. A considerable amount of pressure is required to overcome the spring tension when moving the operating arms. However, the arms can be moved enough so that the end of the cylinder can be moved out of the spring clip. After the ball end of the cylinder or the piston rod is moved out of its seat, slowly release the operating arm exercising care to prevent injury to the fingers or hand.

The opposite end of the operating cylinder may then be disconnected simply by spreading the spring clip.

22—TOP OPERATING CYLINDER REPLACEMENT

With the top raised, remove the nut from the yoke and linkage attaching bolt shown in figure 20.

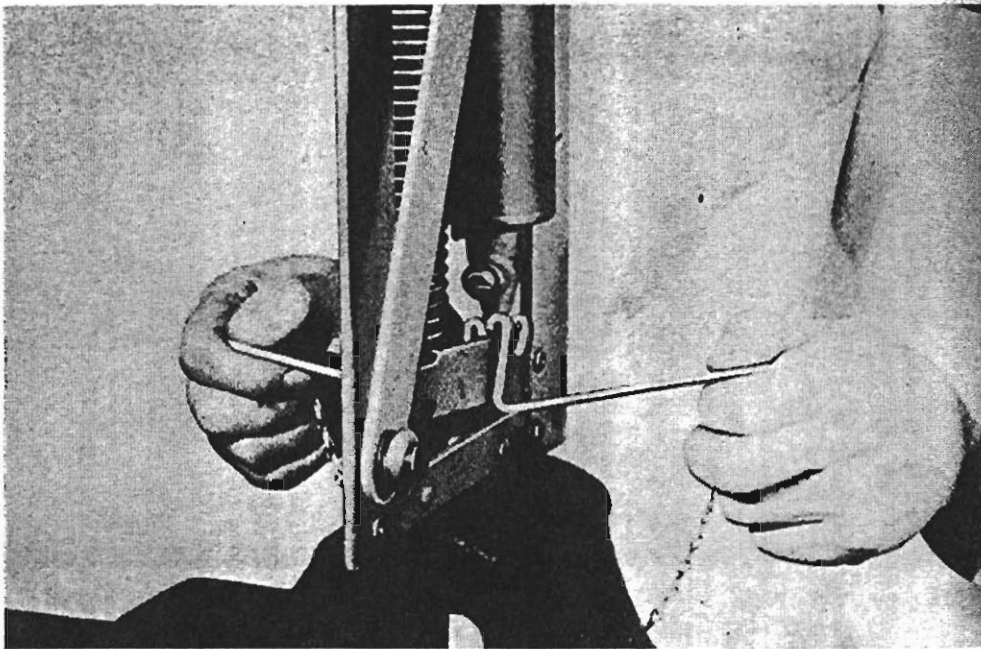

Fig. 19—Secure Assembly in Vise and Spread Spring Clip with Special Spring Clip Remover.

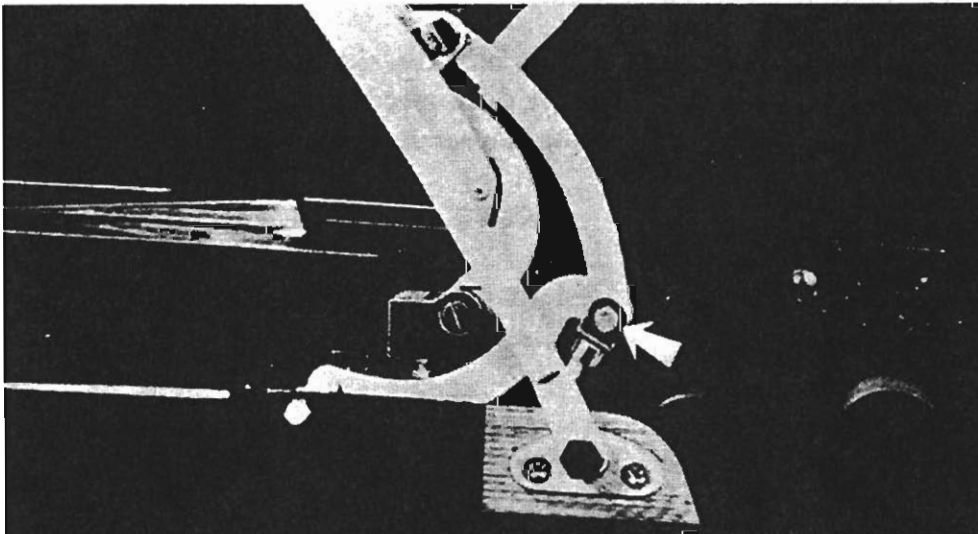

Fig. 20—With Top Raised, Remove Nut from the Yoke and Linkage Attaching Bolt Indicated by Arrow.

If the top operating mechanism is operative, lower the top using hydraulic power. If the mechanism is inoperative, remove and empty the fluid reservoir. After the empty reservoir has been replaced, pull out the top operating control knob and lower the top by hand.

NOTE

It is necessary to empty the reservoir before lowering the top by hand since the flow of the fluid is not the same as when the

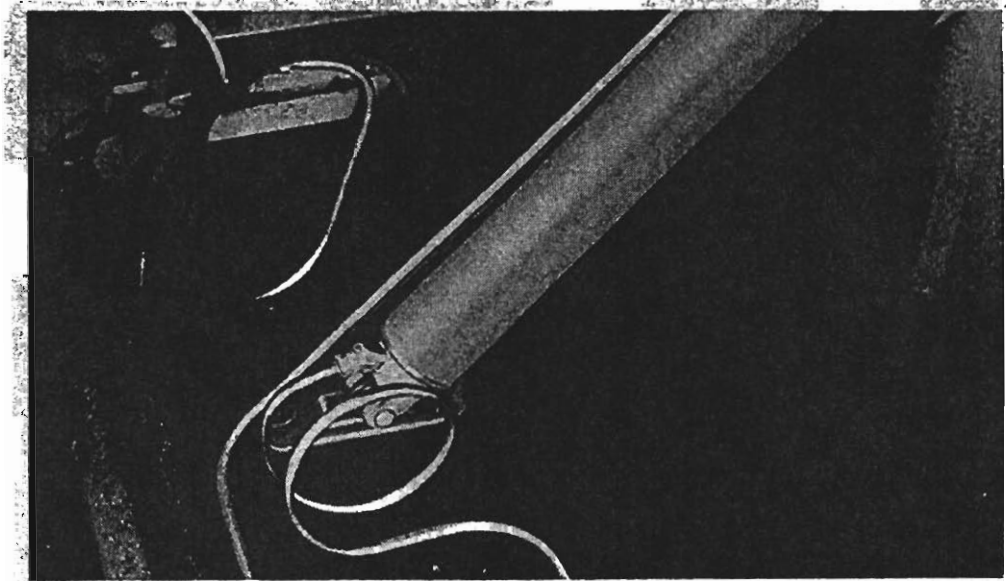

Fig. 21—Remove Clevis Pin Connecting Lower End of Top Operating Cylinder to Floor Pan Anchor Plate.

pump is operating. Fluid is being returned to the reservoir but none is being pumped out.

Remove the rear seat, seat back, and the side rear trim section. Tag or mark any wires which may be disconnected so they may be attached to their proper terminals during the reassembly operation.

NOTE

If the wires are not tagged or marked when disconnected refer to the wiring diagram, figure 28, when connecting the wires during the reassembly operation.

Disconnect the tubes from the fittings in each end of the operating cylinder.

Remove the bolt shown in figure 20 from the top linkage.

Remove the clevis pin which holds the lower end of the cylinder to the anchor plate attached to the floor pan as shown in figure 21 and remove the cylinder.

The cylinder may be replaced by reversing the removal procedure outlined above. Replacement cylinders are shipped full of fluid but, if reinstalling a cylinder, move the piston rod to the fully "lowered" position and fill the cylinder with fluid through the opening at the upper end. This will greatly reduce the amount of air which will be in the system when the tubes are connected and the system refilled.

Before reinstalling the trim panel, seat, etc., operate the top several times to dispel all air from the system. While the top is being operated, the connections also should be checked for fluid leakage.

23—TROUBLE SHOOTING

1. *One window will not quite close:*
 - a. Insufficient fluid. Refer to operations 2 and 5.
 - b. Window binding. Refer to operations 6 and 7.

2. *Two windows operate from one switch:*
 - a. Wires touching on cylinder solenoid circuit. Refer to figure 28 and check wiring.
 - b. Pump pressure too high. Refer to operation 11.

3. *Windows, seat, and top fail to operate in either direction:*
 - a. Battery gravity reading low. Refer to operation 1.
 - b. Defective circuit breaker. Refer to operation 12.
 - c. Insufficient fluid. Refer to operations 2 and 5.
 - d. Defective solenoid relay switch. Refer to operation 13.
 - e. Motor brushes or commutator dirty or fields or armature shorted. Refer to operation 10.
 - f. Battery ground wire loose or terminals in control circuit loose or corroded. Refer to figure 28 and check wiring.

4. *One window only or seat fails to operate in either direction:*
 - a. Defective control switch. Refer to operations 16 and 17.
 - b. Defective operating cylinder solenoid valve. Refer to operations 15, 18, 19, 20, and 21.
 - c. Window or seat binding. Check seat tracks and refer to operations 6 and 7.
 - d. Open circuit or short circuit in wiring. Refer to figure 28 and check wiring.

5. *Windows all operate slowly in down direction—seat in backward direction only—top in either direction:*
 - a. Fluid congealed due to cold or not having been changed at regular intervals. Refer to operation 3.
 - b. Pump relief valve piston sticking. Refer to operation 11.

6. *Windows all operate slowly in up direction and seat in forward direction only—top in either direction:*
 - a. Pump relief valve sticking. Refer to operation 11.
7. *Windows, seat, and top all operate slowly in either direction:*
 - a. Bent or crimped fluid tubing. Refer to figure 27 and check tubing.
 - b. Pump relief valve piston sticking. Refer to operation 11.

TOP ADJUSTMENTS

The following paragraphs describe the various adjustments which occasionally may be required to correct certain variations in the fit of a Convertible top. In some cases, only a single adjustment may be necessary. In other cases, however, a combination of two or more adjustments may be required to correct a variation. In either event, the adjustments should be made so that no undue stress or strain is placed upon one particular section or point in the top assembly.

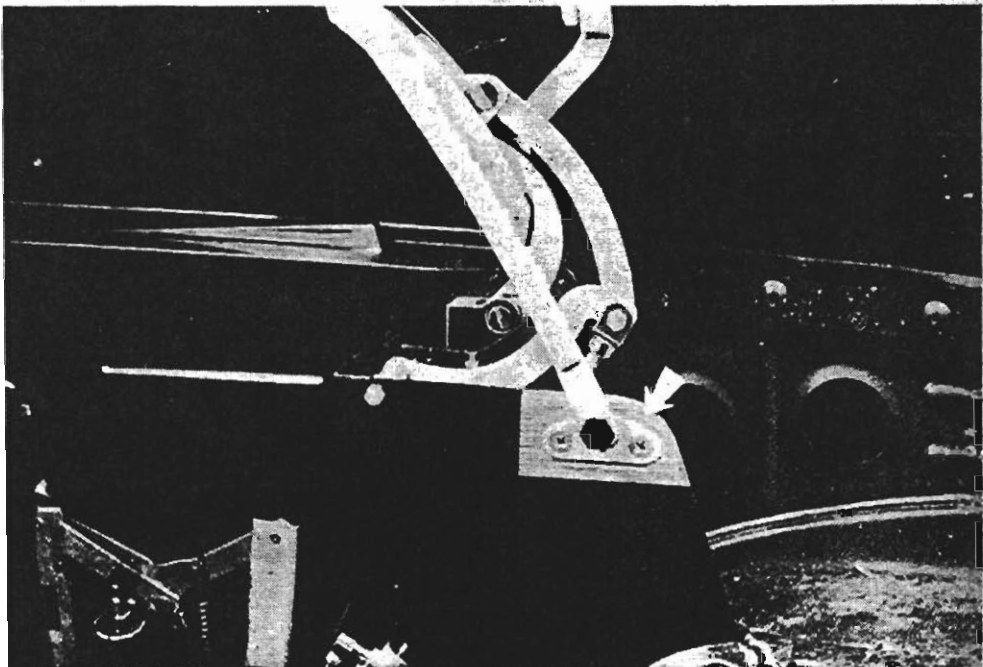

Fig. 22—Side Rail May Be Raised or Lowered by Shifting Serrated Bracket Indicated by Arrow.

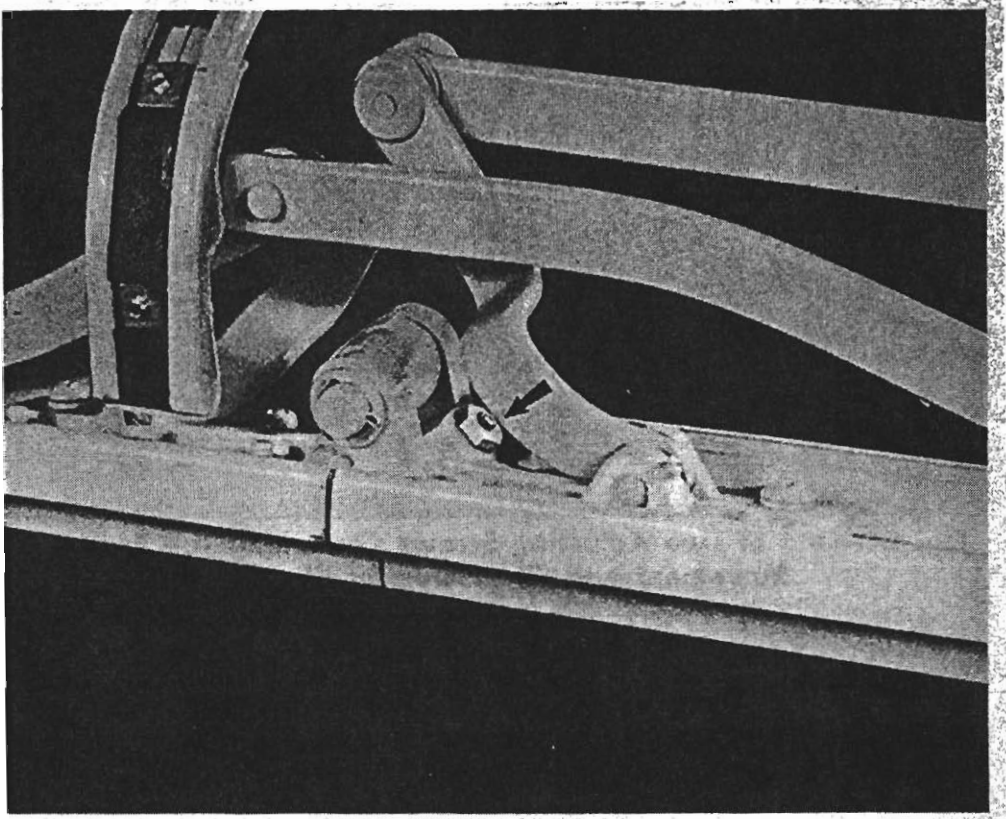

Fig. 23—Hump at Hinge in Center of Side Rail May Be Eliminated by Turning Adjusting Screw.

24—ADJUSTMENT OF SIDE RAIL—HIGH OR LOW

If a side rail is too high or too low in relation to the tops of the door window and the quarter window, the affected side rail may be lowered or raised by shifting the serrated bracket indicated in figure 22. The brackets are attached to panels located on each side of the rear quarter and are accessible without removing the rear quarter trim panels.

To raise a side rail, unlock the top and lower the top approximately half-way. Loosen the three retaining nuts which hold the serrated plate and link assembly to the panel and move the plate downward. To lower a side rail, unlock and lower the top approximately half-way, loosen the three retaining nuts, and move the plate upward.

25—HUMP OR SAG IN CENTER OF SIDE RAIL

The adjustment for correcting a sag or an objectionable hump at the hinge in the center of the side rail above the door window is shown in figure 23.

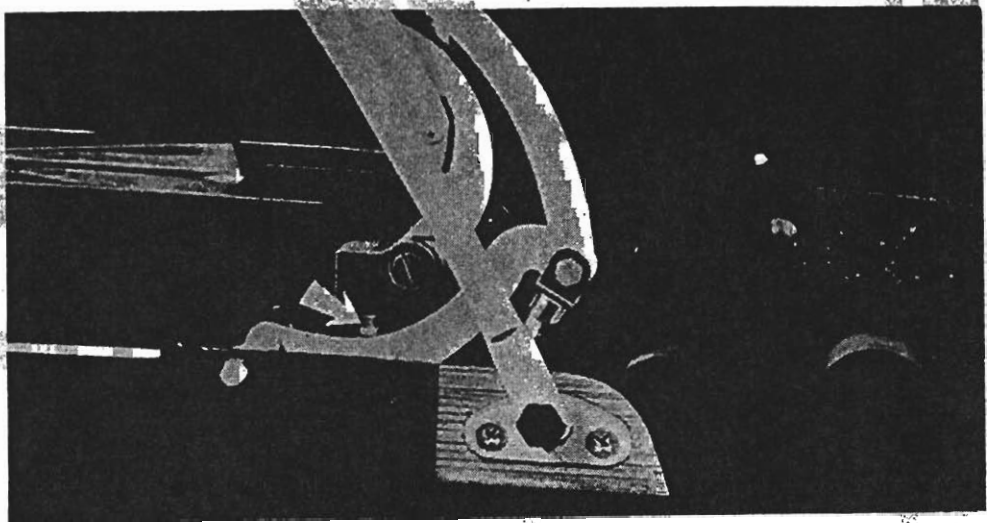

Fig. 24—One of Two Adjusting Screws Controlling Top Forward Movement and Fit at Quarter Window.

When properly adjusted, the inner ends of the two rails which form the side rail should be slightly above horizontal where they are jointed together at the hinge.

If the side rail has sagged at the hinge, loosen the adjusting screw locknut and turn the adjusting screw out. If the side rail is too high at the hinge, turn the adjusting screw in until just a slight rise is noted at the hinge.

26—HEADER DOES NOT DROP FAR ENOUGH

When raising the top, the header should just drop to the top of the three locking dowels when the raising cycle is completed.

If the header does not drop far enough and undue effort is required to pull the header down to its locking position, loosen the serrated plate shown in figure 22 on both sides and move the plates upward until the header just drops to the tops of the dowels.

27—GAP OR INSUFFICIENT CLEARANCE AT QUARTER WINDOW

Figure 24 shows one of the two adjusting screws which control the forward movement of the top. These screws also control the fit of the top at the curved rear section of the quarter window. While these adjusting screws are hidden from view they are, nevertheless, accessible without removing any of the rear quarter trim.

If a gap exists, as shown in figure 25, between the curved rear section



Fig. 25—If Top Gaps as Shown, Turn Adjusting Screws "In". If Too Close, Turn Screws "Out".

of the quarter window and the weatherstrip attached to the curved rear top rail, loosen the adjusting screw locknut and turn the screw in until the gap is closed.

If the curved rear top rail fits too tightly against the quarter window at this curved rear section, causing the weatherstrip to be tightly compressed, loosen the locknut and turn the adjusting screw out until the pressure is relieved.

28—HEADER ALIGNMENT ON LOCKING DOWELS

After raising the top, the header should be in a position which will permit the locking dowels to centrally enter into the dowel holes when the header is pulled down and locked.

Proper alignment may be obtained by loosening the retaining screws and nuts, shown in figure 26, and moving either or both ends of the header forward or back. Elongated holes at these points permit the fore and aft movement of the header.

29—ADJUSTMENTS BEFORE INSTALLING NEW TOP FABRIC

Loosen the adjusting screw locknuts and turn the adjusting screws, figure 24, all the way in.

Position the serrated brackets, figure 22, so the retaining screws are centralized in the elongated holes in the panels and then tighten the retaining nuts.

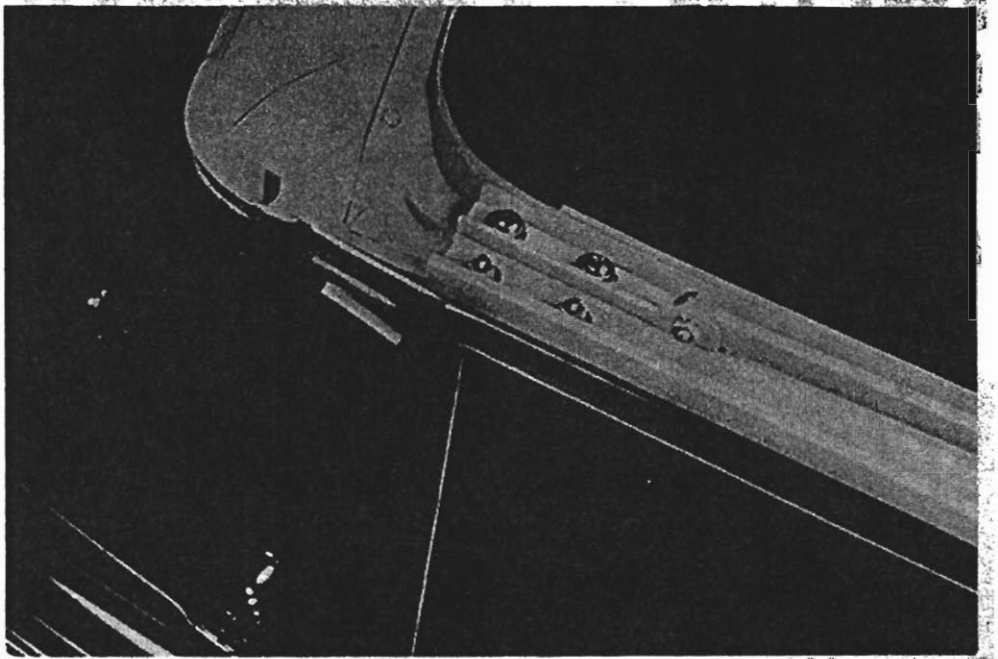

Fig. 26—Adjust Header Alignment with Locking Dowels after Loosening Retaining Screws and Nuts.

Raise the door and quarter windows and adjust the fit of the top at the quarter windows as described in operation 27.

Make the adjustment at the hinge in the center of the side rail as described in operation 25.

Adjust the header travel as described in operation 26.

Adjust the header alignment on the dowels as described in operation 28.

Install the top fabric.

Fig. 28—Wiring Diagram of Hydraulic System.

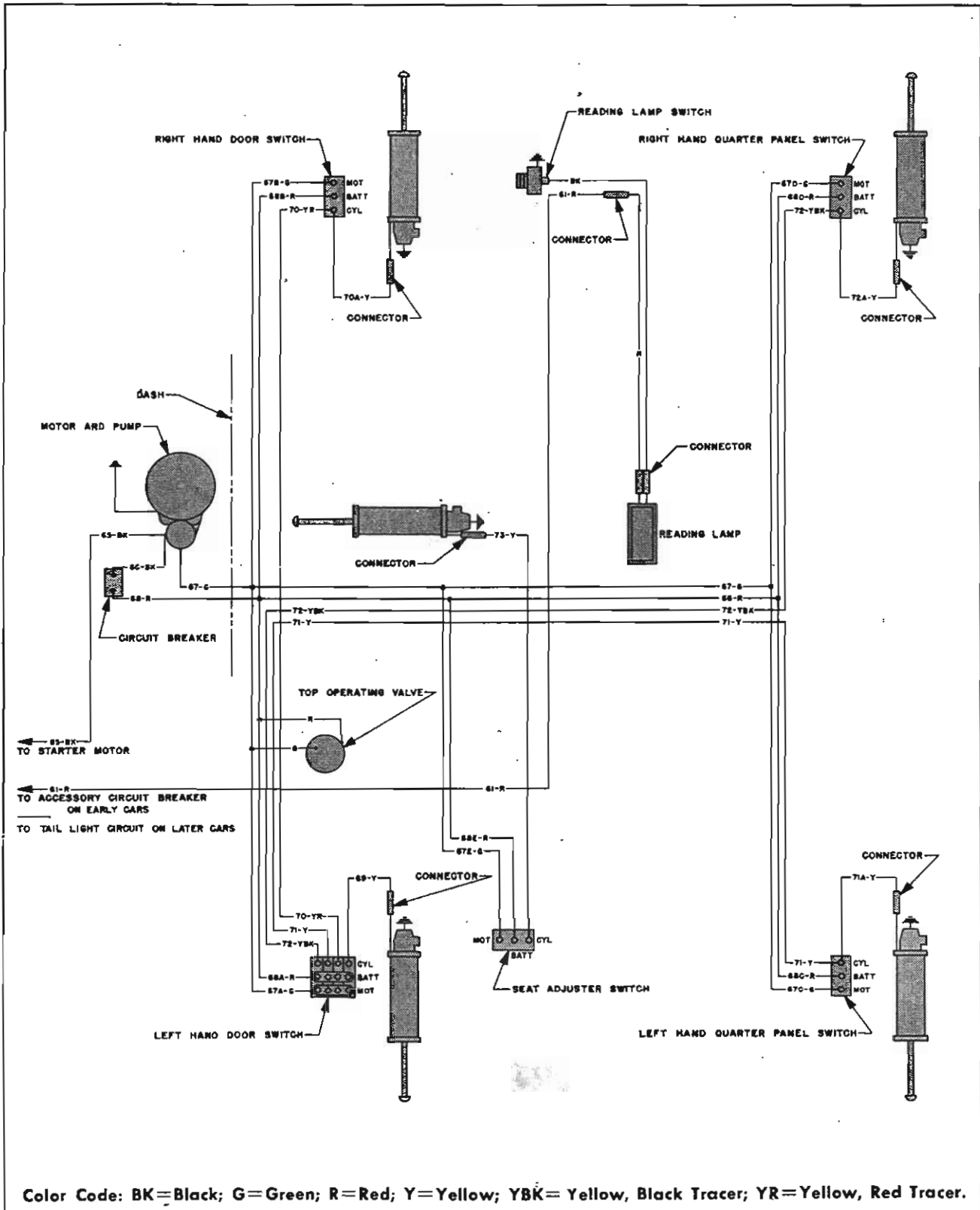

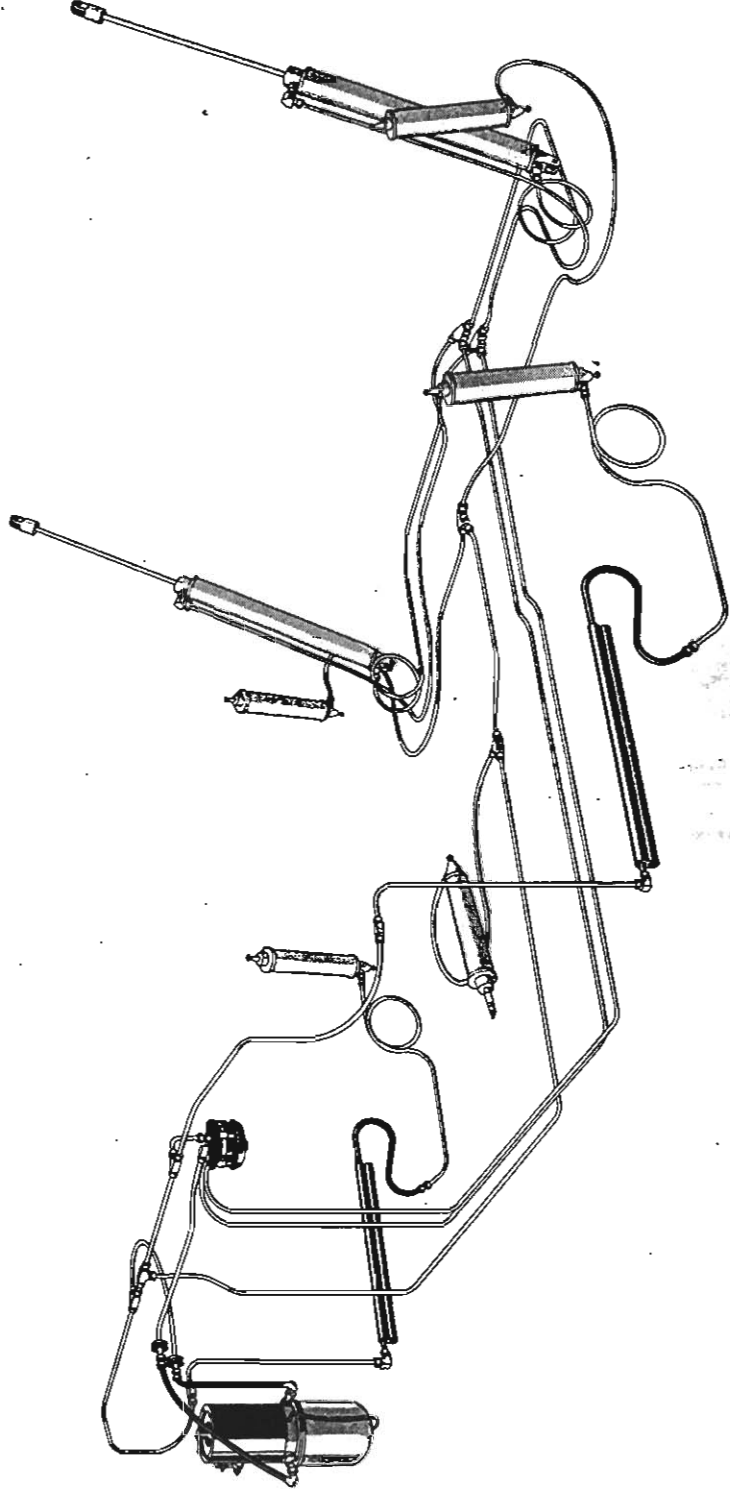

Fig. 27—Schematic View of Hydraulic System Showing All Assemblies, Tubing, and Connections.